

FLAME WHEEL WIRING DIAGRAM - F550 Y6 Tricopter.

Channel	1	2	3	4	5	6	7	8
Frequency	5866MHz	5847MHz	5828MHz	5809MHz	5790MHz	5771MHz	5752MHz	5733MHz
	9	10	11	12	13	14	15	16
	5949MHz	5929MHz	5909MHz	5889MHz	5869MHz	5849MHz	5829MHz	5809MHz
	17	18	19	20	21	22	23	24
	5729MHz	5749MHz	5769MHz	5789MHz	5809MHz	5829MHz	5849MHz	5869MHz
	25	26	27	28	29	30	31	32
	5729MHz	5749MHz	5769MHz	5789MHz	5809MHz	5829MHz	5849MHz	5869MHz

Collected 2.4Ghz control system with 5.8Ghz image transmission function
Build-in 32 channels to receive 5.8Ghz real-time images

RX1002 - 2.4G Reciever

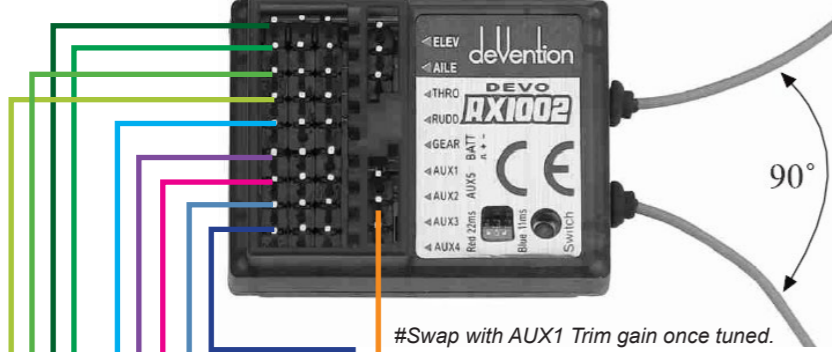

- FUNCTION - NAZA - RX1002 - F12E
 - Fwd/back - E - ELEV - Right Stick
 - Left/Right - A - AILE - Right Stick
 - Height - T - THRO - Left Stick
 - Rotate - R - RUDD - Left Stick
 - GPS/ATI/Manual - U - Gear - Mix SW
 - Trim gain - X1 - AUX1 - AUX7 SW
 - IOC - X2 - AUX2 - AIRE D/R
 - Gimbal Roll - - AUX3 - AUX5 KB
 - Gimbal Pitch - - AUX4 - AUX6 KB
 - Camera Vid/Pic - - AUX5 - FMOD SW
 - Failsafe - - - Gear SW
 - Cam Zoom - - # - unused
 - Cam on/off - - - unused
 - Gimbal Pitch - - unused - AUX6 KB
- F12E > Model Menu > Device Output
* 4S 16.6v-13.4v 6600mAh LiPo Battery

F12E Controller/Transmitter



FT952 - Video Transmitter

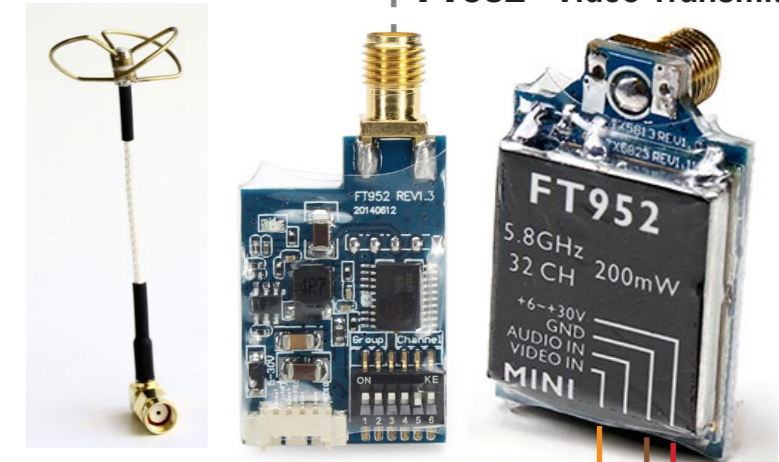

iOSD - Displays live data on remote screen - voltage, GPS, direction, height, distance etc.

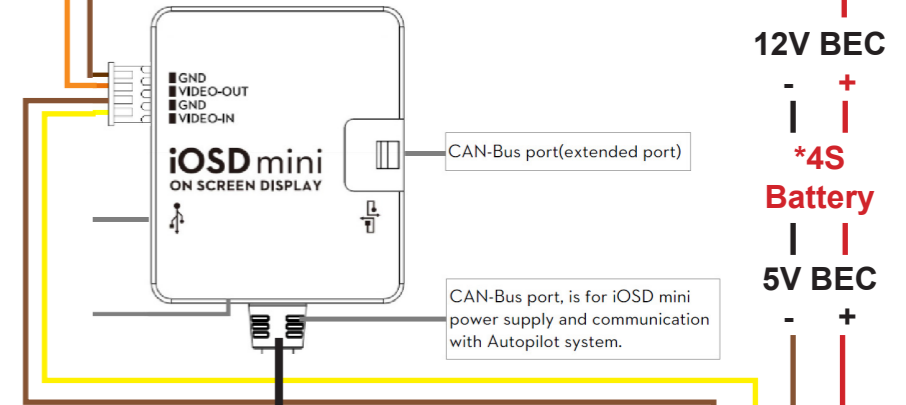

NAZA M V2 - Flight Controller

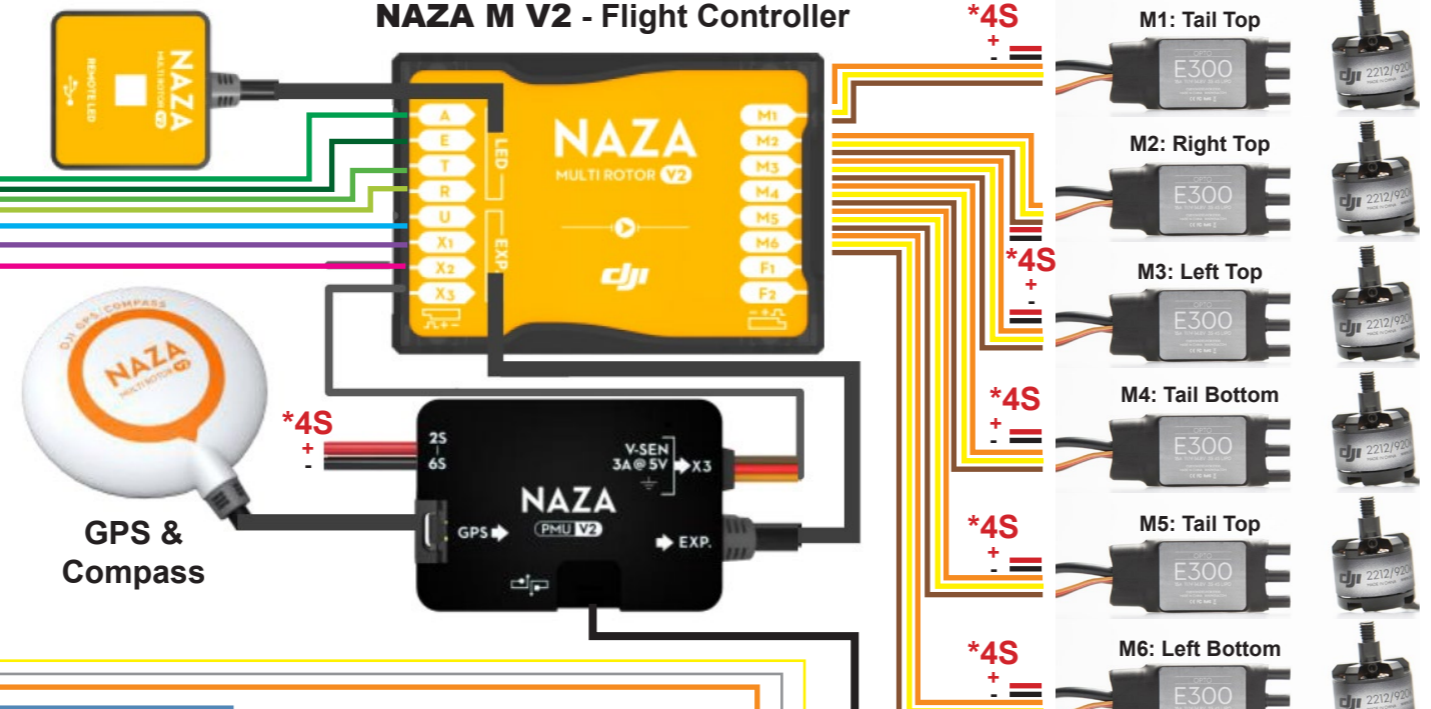

HDMI - AV RG03916 Digital to Analogue Video Converter



Sony RX100 III - Camera



iFlight G40 Gimbal with Alexmos 32 bit BGC controller



gentWIRE-MULTI Camera Controller

